

ROUGH

SCIENCE

The Thinking Person's Reality Show

ADVENTURE ACTIVITY GUIDE

ACKNOWLEDGEMENTS

For WETA

Director of Outreach and Education
Ferne C. Barrow

Editorial Coordinator
Karen Zill

Designer
Cynthia Aldridge

Illustrator
Christopher Zaccone

Editor
Barbara deBoinville

Executive Producers
Dalton Delan
Jeff Bieber

For the BBC

Executive Producers
Karen O'Connor (Episodes 101-106)
Andrew Law (Episodes 107-110)

Series Producers
Steve Evanson (Episodes 101-106)
Paul Manners (Episodes 107-110)

Project Advisors

Angela Birch
Imperial College of Science,
Technology and Medicine
London, UK

Mike Bullivant
The Open University
Milton Keynes, UK

Kimberlie McCue
Missouri Botanical Garden
St. Louis, MO

Dennis Schatz
Pacific Science Center
Seattle, WA

Kendall Starkweather
International Technology Education Association
Reston, VA

Peter Taylor
The Open University
Milton Keynes, UK

Educational materials produced
by the New York Hall of Science

Director of Public Programs
& Special Events
Marcia Rudy, Ph.D.

Director of Education
Preeti Gupta

Director of Science
Martin Weiss, Ph.D.

Manager of Public Programs
Sylvia Perez

Supervisor of Public Programs
& Science Theater
Marcos Stafne

Manager of Science Programs
Frank Signorello

Science Program Assistant
Grace Jose

Exhibit Developer
Rita Hoffstadt

Web site

Look for more information about
Rough Science on the World Wide web:
www.pbs.org/roughscience.

To purchase videotapes or DVDs of
Rough Science programs, contact:

Bullfrog Films
P.O. Box 149
Oley, PA 19547
1-800-543-3764

Order online at www.bullfrogfilms.com

CC Closed captioned for viewers who
are deaf or hard of hearing.

All photos courtesy BBC.

INTRODUCTION

Everywhere you look you can see the fruits of scientific effort and technological innovation—from mobile phones to medicines, from the clothes we wear to the foods we eat. In the natural world, science has shed much light on the value and function of plants and animals and the interplay of various life forms and habitats. Scientists have opened our eyes to a startling, exciting and sometimes bewildering universe, and technology has given us a host of practical uses for the discoveries of science.

Yet, in spite of the ubiquitous nature of science, many people find the subject daunting and inaccessible. *The Rough Science* television series hopes to change that. By showing how science can be put to use in everyday life, *Rough Science* helps viewers understand that science is a process involving some basic knowledge, a good dose of curiosity, a little guesswork, trial and error, and a bit of elbow grease to find solutions.



Kate Humble samples homemade toothpaste.

The *Rough Science Adventure Activities Guidebook* is a companion to the *Rough Science* television series. The guide provides science and technology activities that encourage collaborative learning and experimentation in an informal setting. Although written for museum professionals, the guide presents activities of interest to teachers, parents, and students. The activities could be completed not only in a museum but also at school or at home. The activities that were chosen for the guide reinforce the scientific method and inquiry skills, provide interactive, hands-on learning experiences for school age children to adults, and make science and technology fun and engaging.

To request a Guidebook, please write to *Rough Science Guidebook*, WETA, 2775 South Quincy Street, Arlington, VA 22206 or email us at eod@weta.com.



From left, series host Kate Humble, Ellen McCallie, Mike Leahy, Kathy Sykes, Jonathan Hare and Mike Bullivant admire their map-making handiwork.

WHAT IS ROUGH SCIENCE?

Television Series

A thinking person's reality show, *Rough Science* is a ten-part series produced for the Open University in the United Kingdom by the BBC and presented on American television by WETA Washington, D.C. In the half-hour programs, each one set over a three-day period, the cast of British and American scientists must complete specific tasks using only basic tools and equipment and the raw materials they find on their island location. The first six episodes were filmed on Carriacou in the Caribbean; the final four were filmed on the Italian island of Capraia in the Mediterranean. The five engaging scientists in each episode represent the fields of chemistry, botany, physics, virology and biology. See page 18 for biographical sketches of the scientists. A synopsis of each episode is on the inside back cover. The science topics covered in the television series and related activities include weather and orienteering; chemistry, biology, and botany; electricity; astronomy; and physics.



With the intent of creating a celebratory sound, Kate Humble and Jonathan Hare prepare to manufacture the big bang.

Outreach

The *Rough Science* television programs serve as a springboard for the education and outreach activities described in this guidebook. Called *Rough Science Adventures*, these activities give viewers the chance to experience challenges similar to those faced by the scientists in the programs. Because the activities are based on the National Science Education Standards, science and technology teachers may find them a valuable source of enrichment in the curriculum. Public television stations as well as other community organizations can also offer *Rough Science Adventures*

to their constituents. The television series and the Guidebook are innovative means of involving people of all ages and backgrounds in hands-on science in friendly, recognizable environments.

Web site

The companion Web site, www.pbs.org/roughscience, contains descriptions of each program, biographies of the scientists, their production diaries, resources for educators, and additional challenges that viewers can try on their own.



Kathy Sykes is hard at work on an island map constructed from leaves.

Rough Science Adventures at the Museum

This guidebook was written for museum professionals to use with different audiences: young people in elementary school, middle school, and high school, adults, families and groups of mixed ages. It covers a wide array of science and technology topics that touch on everyday living, and the activities can be adapted to all ages and skill levels. They also can be tailored to enhance current museum exhibits and programs. For example, the activities can be used at a variety of multi-day or one-time only events such as:

- school group visits
- after-school programs
- summer camp programs
- scout badge programs
- sleepovers at the museum
- discovery days
- family nights
- member and corporate events
- teacher professional development days
- holiday programs for the general public with drop-in workshops
- outreach with community organizations, libraries, or schools
- field trips to natural habitats

Rough Science Activities

The activities selected for inclusion in the guidebook are similar to activities already used in museums with multi-age visitors. Like the television series, the activities have an island theme. They have been grouped into eight scenarios: Water Quality Control Center, Weather Station, Island Power Plant, Island Observatory, Island Restaurant, Tropical Island Day Spa, and Tropical Island Party. (An additional scenario, Island General Store, appears on the *Rough Science* Web site.) These scenarios can serve as the starting point for a variety of museum or community events described earlier.

Each scenario begins with a brief, scene-setting statement. This introductory paragraph can be used by the educator as a script to involve the participants. Feel free to ad lib or embellish as appropriate. Approached in order, the scenarios provide cumulative learning for participants, but each is designed to stand-alone. The order of activities may be changed and activities added from other scenarios. For example, the making soap activity presented in the Tropical Island Day Spa can be used for Island General Store, Island Restaurant or Tropical Island Party.

After the introductory paragraph, each scenario issues several “challenges,” explains the science behind the activity, lists the needed supplies, and describes step-by-step how to proceed.

Note: A list of scientific supply companies can be found on the Rough Science Web site, www.pbs.org/roughscience, under Discover More.

You may choose to substitute activities that you have developed for your particular audience or that complement other aspects of your programming. Alternatively, you may choose to issue some of the challenges to your participants, provide them with the appropriate materials, tools, and equipment, and let them come up with a variety of solutions to each challenge, providing only as much guidance as they need.



Ellen McCallie employs fire to aid in the creation of sunscreen.

How to Organize Rough Science Events

Plan to screen one or more of the *Rough Science* episodes as part of your event. (Tapes can be purchased from Bullfrog Films; see inside front cover.)

Engage participants in challenges similar to those portrayed in the series. (See *Rough Science* Adventure Scenarios section starting on page 4.)

Take participants on field trips to natural habitats and involve them in activities that relate to the geology, flora and fauna of the area.

Draw on the resources the museum already has: educators, scientists, engineers, volunteers, and technology experts on staff. If possible, invite local scientists, technology teachers, and engineers who may complement your skills and knowledge.

Connect challenges with current exhibits and permanent collections whenever possible.

WATER QUALITY CONTROL CENTER

That tropical water really looks inviting! Looks can be deceiving. Before you jump in for a swim, do a little rough science to check if that water's as pure as it looks.

The Challenges!

To determine if the water is polluted, [test the acidity of the water](#).

To determine if the water has a high or low mineral content, [test the hardness of the water](#) in a soap solution.

To see what organisms are in the water, [make a microscope](#).

To make sure that your drinking water is safe, design and [build a water filter](#).

Test the Acidity of Water

We want to know if the water on your island is acidic or basic (alkaline). Strongly acidic or strongly alkaline water can be a sign of pollution and can be harmful to plants and animals and hazardous to drink. Carry out the following test to check your water.

You need

- a red cabbage
- medium-size bowl
- grater
- strainer
- small plastic or glass pitcher
- 5 clear plastic cups
- baking soda
- lemon juice
- vinegar
- cola
- distilled water
- "island" water (spiked with something acidic like vinegar)
- teaspoon

What you do

Grate one cup of red cabbage into a medium-size bowl and cover it with 1/2 cup cold distilled water. Let it sit for 45 minutes. When the water turns red, strain the cabbage juice into a plastic pitcher. Use the cabbage juice to test for acids or bases. Acids will make the cabbage juice turn different shades of red, and bases

will make it turn different shades of blue. Pour an equal amount of cabbage juice into five plastic cups. Add 1 teaspoon of baking soda (which is a base) to four of the cups. The stronger the acid, the less liquid you'll use to get the original color back. The fifth cup is your control. The color of the juice in the cup with just the baking soda is the color that you want to get all of your mixtures to match.

Add the lemon juice, 1 teaspoon at a time, to your first cup. How much lemon juice did you have to add to get the cabbage juice back to its original reddish color? In the second cup repeat for vinegar, and cola in the third cup. The liquids you need to use the least of are the most acidic. The liquids you need to use the most of are the least acidic. The liquids that don't change the color at all are bases. Now that you have a range of reactions for comparison, test island water in the fourth cup. What is your conclusion? Is it acidic or basic?

What's going on?

Red cabbage juice is an indicator. When it comes into contact with a base, like baking soda, it turns blue/purple. When it's mixed with an acid, like vinegar, it stays red/pink. Pure water is neutral — neither acidic nor basic.

Test the Hardness of Water

Water can be "hard," even though it's a liquid. Hard water contains lots of minerals (such as magnesium and calcium) that leave deposits in pans and water pipes. Hard water also makes it difficult to lather up with soap. Are you concerned about the lack of lather when you soap up on the island? Test your water to see how hard it is.

You need

"island" water	tall drinking glass
two screw-top jars	distilled water
teaspoon	liquid soap
eye dropper	Epsom salts
small open jar	measuring cup

What you do

In the small jar mix a teaspoon of the liquid soap with 1/2 cup of the distilled water to make a soap solution. In the tall glass dissolve 1 teaspoon of Epsom salts in 2 cups of distilled water to make hard "island" water. Pour distilled water into one screw-top jar and the same amount of "island" water into the other. Use the dropper to put one drop of soap solution into the jar of island water. Screw the lid on tight and shake. If the water doesn't foam, add another drop of solution, screw on the lid, and shake it again. Repeat until the water

foams. Count how many drops of soap solution you need. Repeat the experiment using the screw-top jar of distilled water. Which water needed more drops of soap solution to make it foam?

What's going on?

Distilled water is "soft." We can use it as a measure of the hardness—the mineral content—of the "island water." In hard water the salts (magnesium and calcium) interact with soap to form a scum that will not form bubbles (soap foam). Therefore, the amount of lather is related to the hardness of the water.

Build a Water Filter

Worried about the quality of drinking water on the island? Filtering is one of the best methods of making water safe to drink. This filter will remove small particles from dirty water. Make your own filtered water using this method.

You need

2-liter soda bottle with cap
serrated knife
napkins or paper towels
gravel, sand, charcoal, and cotton balls for the filter
dirty water (if your "island" water looks too clean, add cooking oil, food coloring, pieces of paper, or tiny pieces of Styrofoam)

What you do

Remove the plastic sheath from the outside of the soda bottle and screw on the cap. Cut the bottle in half. Put the top half of the bottle upside-down (like a funnel) into the bottom half. Line the upside-down half-bottle with a napkin or paper towel. Put layers of gravel, sand, charcoal, and cotton balls inside the top half of the bottle. (Ask participants to predict what they think each of the filter materials will remove from the water.) Remove the bottle cap. Pour the dirty water through the filter. (Ask participants to comment on any changes they notice and how their observations fit with their predictions.) Now scoop out each layer of the filter and examine

what each layer has taken out of the water. Experiment by putting the filter materials into the bottle in a different order each time. What difference does the order of the layers make? Clean the bottle halves thoroughly before you use them again.

What's going on?

Different materials filter different substances from the water. The slower the water travels through a material, the more impurities are removed. Here the cotton fibers and sand create a longer path for the water and solids get trapped. Charcoal particles are charged (like a glass rod rubbed with a silk cloth) and they attract oppositely charged impurities.

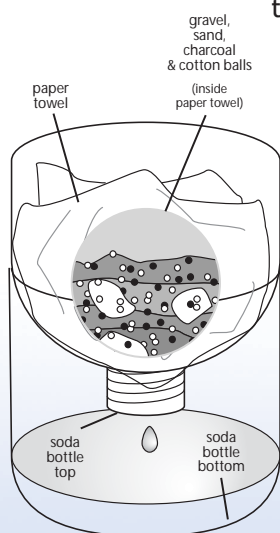

Water Filter For more activities, see the *Rough Science* Web site: www.pbs.org/roughscience.

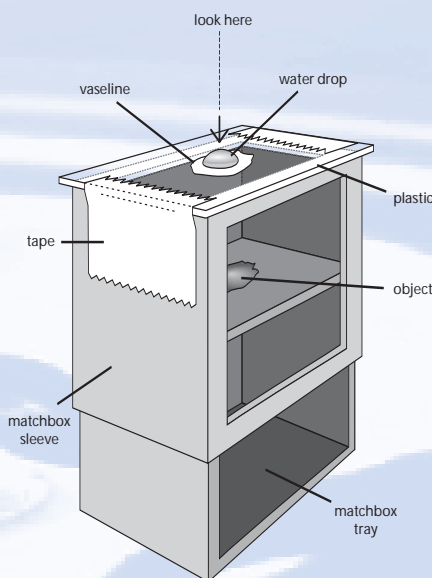

Microscope

Make a Microscope

Water is full of plants and animals that are too small to see with the naked eye. Make a simple microscope to see if you can detect any tiny organisms swimming around in the water.

You need

empty matchbox
piece of thin, transparent plastic (e.g., from a plastic bag or plastic wrap)
matchstick
petroleum jelly or lip balm
dropper
scissors
transparent tape
water samples (e.g. from an "island" pond)

What you do

Cut out most of one of the large sides of the matchbox sleeve. Be careful not to cut it all out since the sleeve still needs to hold together. Next cut a piece of thin, transparent plastic the same size as the end of the sleeve (where the tray slides in). Tape the plastic across the end of the sleeve, taking care to keep the tape right to the edges. Cut a hole in the side of the sleeve to allow light to enter. With the plastic-covered end up, slide the sleeve onto the tray of the matchbox (as if to close the matchbox) with the hole on the open side. Using the matchstick, draw a circle of petroleum jelly on the plastic. Use the dropper to place a single drop of water in the circle. Put another drop of water (pond water) on the end of the tray and look at it through your magnifying water drop. Very carefully, slide the sleeve up or down to focus your microscope. This matchbox setup can also be used to view other items like small insects.

What's going on?

This is a simple type of light microscope that bends light reflected by an object to make a larger magnified image.

Activity adapted from *How to Build a Mini Microscope*, <http://physics.about.com>.

WEATHER STATION

The weather in the tropics can be unpredictable. And there's no radio or TV station to turn on and get a reliable forecast. That's why you'll need a weather station to figure out what changes lie ahead. You'll want advance warning if that big storm is on the way. And you'll want to know which direction it's coming from.

The Challenges!

To calculate the moisture content of the air, [find the dew point](#).

To predict changes in the weather, [make a barometer](#).

To find out which way is North, [construct a compass](#).

To determine the wind direction, [build a wind vane](#).

Find the Dew Point

The island climate is completely different from the one you're used to. How do you avoid getting caught in a torrential storm or a thick fog? The dew point is the temperature at which moisture in the air begins to form dew. It is a way of gauging the air's humidity. Here's a way to calculate it.

You need

tin can	paper towel
thermometer	bowl
tablespoon	water
ice cubes	

What you do

Crush the ice cubes in the paper towel using the back of the tablespoon. Fill the bowl halfway with crushed ice. Make sure the outside of the tin can is completely dry. Fill the can with cold water. Place the thermometer in the can. Add one tablespoon of crushed ice and stir. Continue adding ice until a layer of dew is visible on the outside of the can. Immediately read the thermometer to find the dew point temperature. If it's high, beware! The humidity is high also.

What's going on?

All air contains water vapor. As air cools (when it comes in contact with the cold can), the water vapor begins to condense. This is why glasses holding cold drinks "sweat" in the summertime. The dew point is the temperature at which moisture in the air begins to form dew. The higher the dew point temperature, the higher the moisture content of the air at a given temperature.



Mike Bullivant devises a rain meter as part of the island weather station.

Make a Barometer

A barometer shows changes in air pressure. High pressure indicates good weather, low pressure indicates possible storms. By consulting your barometer every day, you'll be able to make predictions about weather changes. (This can be a multi-day activity to compare the daily differences in air pressure.)

You need

- tall glass or jar
- bowl
- 4 paper clips
- pen
- water

What you do

Slide the paper clips onto the rim of the glass and space them equally

around the rim. Fill the glass about two-thirds full with water. Place the bowl upside down over the glass. Carefully turn the bowl and the glass over so that the glass sits upside down in the bowl. Some of the water will run out of the glass but most will stay inside it. With a pen mark the level of the water in the glass at the beginning of the activity. Take your barometer outside into the open air. Look for changes in the water level in the glass over time. (This may take several hours or even longer than a day.)

What's going on?

When the atmospheric pressure of the air rises, the water in the bowl will be forced downwards by the weight of the air on the

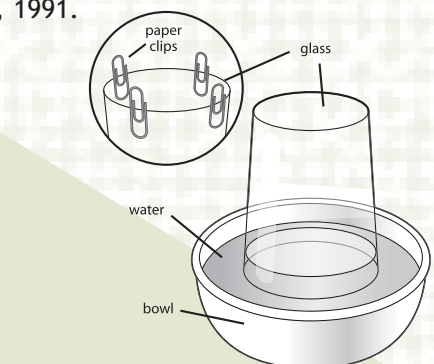

Barometer

water. This, in turn, will cause the water in the glass to rise. A barometer measures the weight of the amount of air between the surface of the earth (the water in the bowl) and the top of the atmosphere.

Activity adapted from Robert Wood. *Science for Kids: 39 Easy Meteorology Experiments*. TAB Books, 1991.

Make a Compass

Make a compass to determine the different directions: North, South, East, and West.

You need

- needle
- magnet
- plastic container
- a cork (1/4" to 1/2 " thick)
- pen
- water

What you do

Fill the plastic container with water. Stroke one end of the magnet along the needle in one direction at least 50 times to magnetize the needle. Lay the needle on the cork, with one end of the needle in the center. Tape the needle down. Float the cork in the container of water. The needle will bob around until it points North, towards the Earth's magnetic north. When the needle settles in position, mark North on the side of the container. Now you can determine the other directions and label them East on the right, South on the bottom and West on the left.

What's going on?

The Earth's core is thought to consist largely of molten iron, which crystallizes into a solid. Convection caused by heat radiating from the core, along with the rotation of the Earth, causes the liquid iron to move in a rotational pattern. It is these rotational forces in the liquid iron layer that lead to weak magnetic forces around the axis of spin. The magnetized needle in a compass can detect very slight magnetic fields. No matter where you stand on Earth, you can hold a compass in your hand and it will point toward the North. This is amazingly helpful because you can tell which way to go no matter what the weather or time of day.

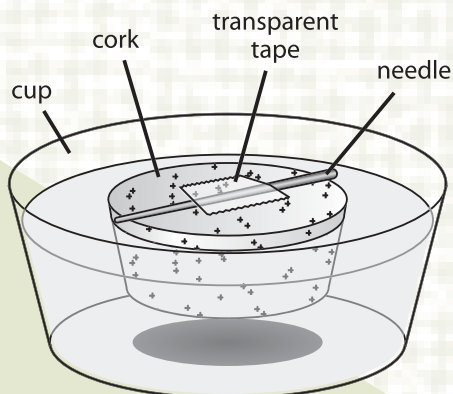

Compass

Build a Wind Vane

A change in wind direction often indicates an imminent change in the weather. Be prepared for sudden change by making this wind vane. (You can also use the compass you made in the previous activity to identify the direction of the wind.)

You need

- a long tack
- scissors
- modeling clay
- a plastic pot or container, e.g., from take-out food
- ruler
- glue stick
- thin, colored card
- drinking straw
- 2 pencils with eraser
- compass

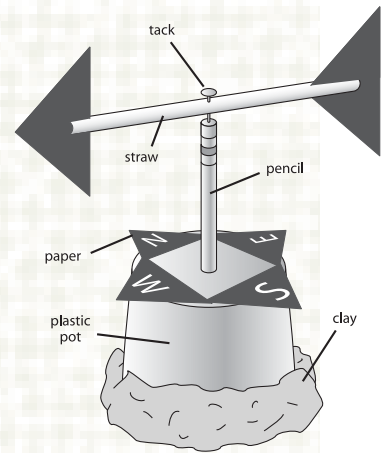

Wind Vane

What you do

Turn the plastic container upside down. Make a hole in the center by inserting the pencil, sharp end first. Make sure that it is firmly in place. With another pencil and a ruler, draw two large triangles and four small ones on the colored card. Then cut out the shapes. Glue the small triangles to the base of the plastic container at equal distances and on opposite sides from each other as on a compass. One point of each small triangle should overlap the edge of the pot, with the pencil in the middle. Cut short slits in each end of the straw and insert one large triangle in each end to make an arrow-shaped "vane." Push the tack through the center of the straw and into the eraser on the pencil sticking out of the pot. Secure the other end of the pot to a surface with a ring of modeling clay. Take the vane outside or to a simulated windy weather area and watch it swing in the wind. Finally, use your compass to determine East, West, North and South, and then label the small triangles accordingly. Now you can tell which direction the wind vane is pointing.

What's going on?

The direction in which the vane points indicates the direction from which the wind is blowing. For instance, in a westerly wind, the vane points "West."

Activity adapted from Neil Ardley. *101 Great Science Experiments*. Dorling Kindersley, 1993, pp. 14-15.

Island Power Plant

Once you've taken care of basics like food and water, you'll want to experiment with ways to create your own electricity and electrical gadgets. Why don't you employ a little rough science to create a power plant on your island?

The Challenges!

To power things, make your own battery.

To drive a paper windmill to create a breeze, build an electric motor.

To see things at night, make your own flashlight.

Make a Battery

Some kinds of batteries produce electricity by a chemical reaction between two different metals (electrodes) immersed in acid (electrolyte). Figure out how to make your own batteries in case the limited supply on the island runs out.

You need

- two wires with the ends stripped off
- aluminum foil
- scissors
- small bowl
- warm water
- salt
- tape
- 6 pennies (copper coins)
- paper towels
- 1.5 volt penlight light bulb
- a paper plate

What you do

Partially dissolve 1 tablespoon of salt in 1 cup of warm water. Some salt should still be evident in the bottom of the bowl. Place a penny on the aluminum foil and draw around it. Repeat five times. Do the same thing with the paper towel. Cut out the circles. You should have six foil circles and six paper ones. Tape the end of one wire to a foil circle. Dip a paper circle in the warm, salty water. Place the foil circle with the wire on the plate, and put a wet paper circle and a penny on top of it. Using all the foil, pennies, and

paper circles, build alternate layers. Then tape the other end of the wire to the last coin and put it on top. This is your battery.

Test the battery with the light bulb. Attach the end of one wire to the metal terminal end of the light bulb.

Wrap the end of the other wire around the metal shaft of the light bulb. Can you see the bulb light up?

What's going on?

The metal atoms in the foil dissolve into the electrolyte (the warm, salty water) and electrons are left behind. Electricity is created when the electrons flow through a circuit (the foil circles and paper circles soaked in warm, salty water). When the metals eventually dissolve completely

into the electrolyte, no more electrons are formed and the battery stops working. The first battery (Volta's Pile) was developed about 1860 by Alessandro Volta. He stacked discs of copper, zinc, and cardboard soaked in salty water in alternate layers and measured an electronic current.

Activity adapted from Neil Ardley. *101 Great Science Experiments*. Dorling Kindersley, 1993. For instructions on creating a similar battery, see <http://isaac.exploratorium>.

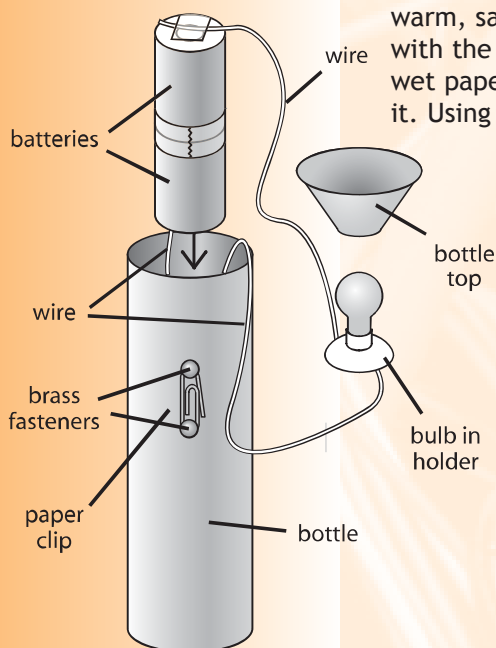
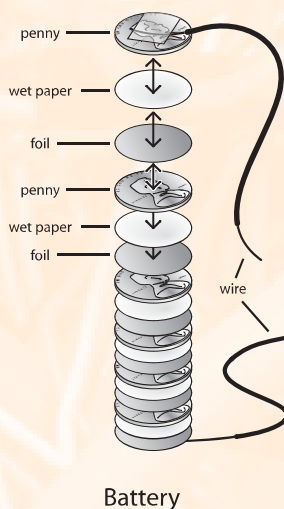

Make a Flashlight

When you're on the island, you can't just flick a switch and turn on a light. There isn't a constant electricity supply. But with a flashlight, you'll be able to see around your room at night and even venture outside for a walk – moonlight or no moonlight.

You need

- | | | |
|---------------|---------------------------------|------------|
| sharp pencil | 3 pieces of wire with bare ends | paper clip |
| screwdriver | empty dishwashing liquid bottle | scissors |
| aluminum foil | 2 batteries with 1.5 volts each | cotton |
| plastic tape | 2 brass paper fasteners | |
| | a light bulb in a bulb holder | |

What you do

Cut the top off the empty dishwashing liquid bottle. Tape foil shiny side up to the inside of the bottle top. Use the pencil to make two small holes in the side of the bottle near the bottom. One hole should be about an inch below the other. Firmly attach two pieces of wire to the bulb holder. Tape the top of one battery to the bottom of the other to make one long battery. Tape the third piece of wire to the bottom of the battery. Tape one of the wires from the bulb-holder to the exposed terminal on the battery. Put the long battery in the bottle, carefully threading the wire from the bottom battery through the lower hole. Stuff cotton in the space between the batteries and the walls of the bottle to keep the batteries in place. Thread the wire from the bulb-holder through the top hole in the bottle. Attach paper fasteners to the two wires poking through the holes and push in the fasteners.

Build an Electric Motor

It's hard to sleep at night because of the heat. How would you go about building a simple motor to turn a paper windmill and create a breeze? When a current passes through a coil of wire it turns the wire into an electromagnet which interacts with a permanent magnet to make the coil spin. The spinning coil is a basic motor.

You need

- 5 small magnets (available at electronics stores)
- 2 large paper clips
- plastic, paper, or foam cup
- 2 feet of solid insulated 20-gauge copper wire (non stranded)
- masking tape
- a 1.5 volt D cell battery in a battery holder
- 2 alligator clip leads (available at electronics stores)
- wire strippers
- broom

What you do

Wind the copper wire around the end of a broom handle to create a coil with a 1-inch diameter. Take each end of the wire and wrap it around the coil to hold the coil together. Leaving about 2 inches of wire sticking out from each end, strip the insulation off these two ends using wire strippers. Attach three magnets to the bottom of the cup with masking tape. Turn the cup upside-down and lay two magnets on top. (The magnets underneath create a strong magnetic field and keep the magnets on top in place with no tape.) Unfold one end of a paper clip and tape it to one side of the cup so that the rest stands up above the cup. Unfold the other paper clip, and tape it to the other side of the cup. The paper

Put the bulb-holder on top of the battery and tape the center of the bottle top over the bulb. In other words, put the bottle top on back-to-front so that the aluminum foil is visible. Bend the paper clip and fit one end under the lower paper fastener to make a switch. (When the switch is turned, current flows from the battery along the wires to the bulb.) Press the other end of the paper clip against the top fastener and see the flashlight light up.

What's going on?

There is a thin wire (a filament) inside the bulb that glows white-hot when current flows through it. The light reflects off the foil to produce a bright beam of light.

For more activities, see the *Rough Science* Web site: www.pbs.org/roughscience.

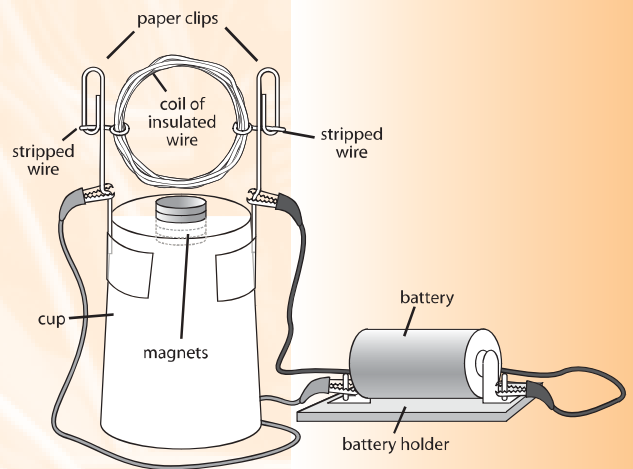

Electric Motor

clips will form a cradle for the coil. Attach one end of the coil to one paper clip and the other end of the coil to the other paper clip. Spin the coil and adjust the height of the paper clips to make sure that there is around 1/16 of an inch between the coil and the top of the magnets. Adjust the clips to make sure the coil stays balanced and centered. Put the battery and battery holder beside the cup. Attach one end of an alligator clip to a battery terminal and the other to a paper clip. Attach the other alligator clip to the other battery terminal and the other paper clip. Spin the coil to start it turning.

What's going on?

The current running through the coil of wire creates an electromagnet. What does this mean? As with a bar magnet, one end of the coil has become a North Pole, and the other a South Pole. Each of the three magnets attracts its opposite pole and repels its like pole of the coil, causing the coil to spin.

Island Observatory

On the island, far away from polluting lights and smog of the city, you check out the spectacular night sky. Using a little rough science, study the solar system while you enjoy the solitude.

The Challenges!

To calculate time at night, make a star clock.

To identify what's in the night sky, make a telescope.

Make a Star Clock

It's night and you want to figure out the time by reading the positions of the stars. Before the invention of clocks, people told the time by the movement of the stars across the night sky. You can do the same using your star clock.

You need

star clock template or print from the Lawrence Hall of Science Web site: <http://www.lhs.berkeley.edu/StarClock/starclockprintout.html>
scissors
brass paper fastener
sharp pencil

What you do

Carefully cut around each star clock circle and poke a hole through the middle of each one. Place the small circle on top of the large circle. Push a paper fastener through the holes in both circles and spread the fastener open on the back of the clock. Go outside, look up at the sky, and using your star clock find the Big Dipper and the North (or Pole) Star. Face the North Star. Put your thumb over the current month. Slide the outer circle around so that your thumb is at the top. Turn the smaller disc carefully until its stars line up with those in the sky. You can now read the time in the window. (If you are on Daylight Savings Time, add one hour.) Compare the time with your wristwatch to see how close you get. It's better to do this activity when the moon is not full. A full moon is so bright that it becomes difficult to see the stars.

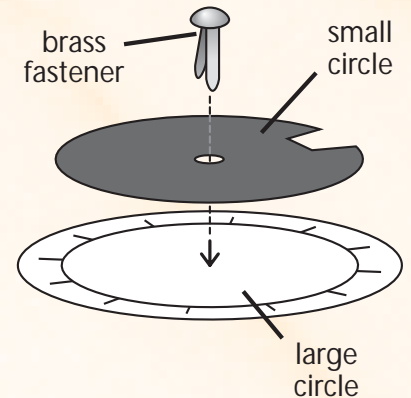

Star Clock

What's going on?

The North Star never appears to move because the Earth's axis, the imaginary line drawn from pole to pole through the center of the Earth, points almost directly to the North Star. The stars that appear to revolve around the North Star are known as circumpolar stars. In mid-northern latitudes, these stars appear to circle around the North Star without rising or setting. The star clock estimates the time based on where the stars appear relative to the North Star.

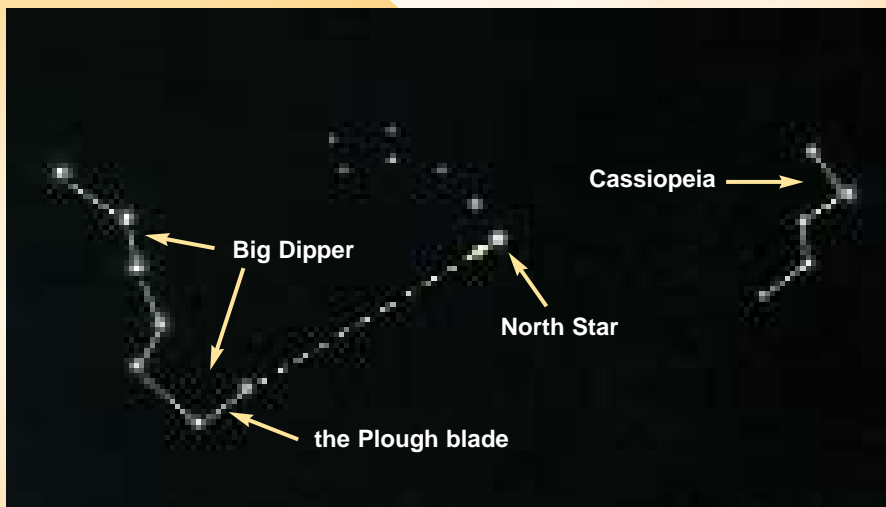

Activity adapted from Lawrence Hall of Science. *Earth, Moon, and Stars*. Regents of the University of California, 1986.

How to locate the North Star.

Make a Telescope

When you first look up to find the Big Dipper to orient your star clock, you may have trouble seeing it. Why don't you make sure you'll find it by making your own telescope? Even if you find the Big Dipper and the North Star with ease, your telescope will help you to see the moon and thousands of other stars in much greater detail.

You need

- 2 convex lenses of different focal lengths (e.g., use 2x and 4x lenses from drugstore reading glasses)
- a cardboard tube at least as long as the sum of the two focal lengths of the lenses
- pen
- tape

What you do

Fix one lens to each end of the tube with tape. Take care not to obscure the view through the tube. Mark the end of the tube with the shorter focal length lens. This will help you figure out which way round your telescope is. Look through this end.



Jonathan Hare and Kate Humble concoct a transmitter.

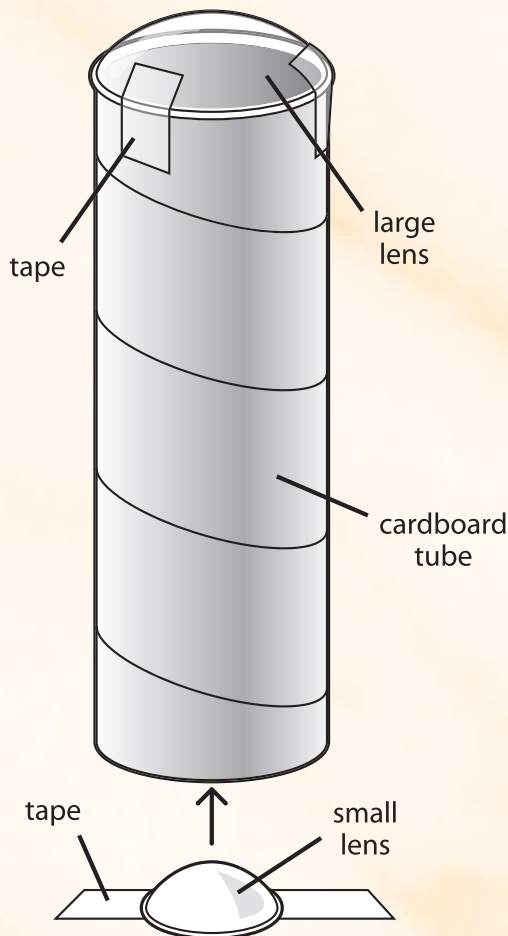

Telescope

What's going on?

Telescopes use lenses to bend the incoming light. The first lens (objective lens) gathers light and bends it into focus and provides a small, upside down image of the object you're looking at. The second lens (the eye-piece) then magnifies the object so that you can see it better. When the two lenses are combined, you have a telescope that magnifies the image.

For more information on how telescopes work, see www.howstuffworks.com.

Suggestions for other activities

To understand the position and distance of different planets and the sun, make a model of the solar system.

To understand the rising and setting of the sun at different points on the Earth, make a solar calculator.

To measure the height of celestial objects in degrees, make a clinometer.

To track the stars that you see, make a constellation chart.

Island Restaurant

If you're on a tropical island, it's great to know there is a restaurant where the food is fresh and the mood is mellow. After you're through with your rough science, don't forget to make a reservation!

The Challenges!

To cook meals for your guests, make a solar oven.

To grow herbs and spices, build a terrarium.

To provide warm water, build a solar water heater.

Make a Solar Oven

Nothing beats home cooking! It's your restaurant and you're the chef. Get creative with the menu. In fact, get creative with the oven. Make your own solar oven to prepare exquisite meals for your guests.

You need

- a box with a lid, e.g., a pizza box
- black construction paper
- aluminum foil
- heavy plastic laminate
- glue
- transparent tape
- scissors
- ruler
- magic marker
- straw

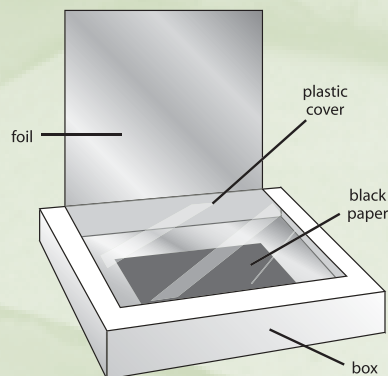

Solar Oven

What you do

Draw a square on the lid of the box and cut along three sides of it. Fold back along the uncut side to form a flap that opens and shuts. Line the inside of the flap with aluminum foil, smoothed over and glued into place. Cut a piece of plastic to fit very tightly over the hole you created in the lid of the box by forming the flap. Use enough plastic to overlap the underside of the flap. Seal the plastic by taping it to the underside of the flap. (The plastic has to be tightly sealed to make sure that no air can escape from the oven.) Line the bottom of the box with foil, and glue it into place. Again, take care to smooth out all wrinkles. Cut out a piece of black construction paper to fit on the bottom and tape it in place. Close the lid (including the plastic window) and prop the flap open, facing the sun. Move the box around to get the maximum amount of sun into your oven. Try cooking something like s'mores. Compare the solar oven with the solar water heater, described on the next page.

What's going on?

Energy, radiating from the sun, reflects off the foil. This heat energy is then stored in the oven.

For more information on solar-powered technology, see <http://www.solarnow.org/pizzabx.htm>.

Build A Terrarium

Spice up your food and garnish dishes with herbs and spices grown in an herb terrarium (herbarium). Your restaurant will become an instant hit once customers realize that their palates will be pampered with subtle flavors. Building a terrarium is much easier than tending a garden, and it's low maintenance.

You need

- a glass or plastic container, such as a candy jar or picklejar, with a wide mouth and tight-fitting lid
- potting soil
- potted herbs
- colored stones
- shells
- water
- soap
- paper towel

What you do

Do some research to select herbs that need similar conditions (soil, light, water) for growth. Take care to choose plants that will not outgrow the container. After cleaning, rinsing, and drying the container thoroughly, fill it full with potting soil. Place the plants in the soil at a depth similar to that in their pots and press

the soil down around them. Squeeze water from wet paper towels to moisten the soil around the plants, but do not overwater or you will kill them. (If you need to, you can add more water at a later date.) Decorate your terrarium with colored stones and shells. Close the lid tightly and place the terrarium where the plants will receive the light they need. You have created a self-sustaining ecosystem.

What's going on?

The lid traps air inside the terrarium. Plants use carbon dioxide and sunlight during the day to produce food and oxygen through photosynthesis. At night, they use the oxygen to create more carbon dioxide. The water trapped inside the terrarium is absorbed through the roots of the plants. It moves up through the stems and evaporates

through the leaves. Like rain, the water will condense on the top of the terrarium and drip back down to the bottom. The oxygen, carbon dioxide, and water are therefore constantly being recycled by the plants.

Make a Solar Water Heater

Wash the sand off after a dip in the ocean with a relaxing warm shower hooked up to a solar water heater. All it takes is a few simple objects and plenty of sunshine!

You need

water jug	black paint
large fish tank with a lid	paintbrush
aluminum foil	water
transparent tape	cardboard, with an area
thermometer	greater than the base of the fish tank

What you do

Line the sides of the tank with aluminum foil, inside and out, and tape the foil firmly in place. Paint the bottom of the inside of the tank black. Place the cardboard in a spot that is in the sun all day. Place the tank squarely on the cardboard. Once the paint is completely dry, fill the tank with water. Put the lid on the tank. Use the thermometer to test the temperature of the water every half-hour. If it gets too hot for a comfortable shower, remove the lid until the water equilibrates with the outside temperature.

What's going on?

Sunlight (infrared energy) passes through the glass and is absorbed by the water. Water has a high heat capacity (able to absorb and hold heat). A black surface absorbs some of the light (sunlight). If trapped, as it is in this case by the insulation (the foil), the heat (energy) accumulates and is reflected into the water so it gets warmer. The heat energy cannot escape as easily back through the glass so the water stays warm.

Kathy Sykes devises an ingenious electrical coil to facilitate cooling the scientists' surroundings.



Tropical Island Day Spa

Hot and sweaty from the tropical sun? What better way to recover than a luxurious day in a spa? Before you slather on that facemask and kick back in the sauna, you're going to have to figure out how to create the essentials for a day of pampering yourself! Discover the rough science behind what happens in a day spa.

The Challenges!

To remove some of those layers of grime, make scented and textured soap.

To clean those pores and keep your skin hydrated and beautiful in the sun, create a facial mask.

Leave that astringent cucumber mask on too long and you'll look like a prune! On an island you won't have a watch or clock so construct a sundial.

Add Scent and Texture to Soap

Soaps are made by boiling oils and fats with an alkali. Because this takes a long time and can be dangerous, we're going to use shredded olive oil soap as our base and add oils and flowers for scent and texture. For safety, ask the soap makers to tie back long hair and roll up their sleeves. Supervise young participants. To dry the soap quicker, place it in the sun or in a low oven for 15 minutes.

You need

- 2 saucepans, 1 large, 1 small
- 1-lb. bar of olive oil soap
- grater
- plastic or glass droppers
- a selection of herbal tea bags (chamomile, green tea, fruit flavors)
- teapot or pitcher
- essential oils such as lavender, geranium, vanilla, sweet almond oil (You can buy herbal teabags and essential oils in health food stores.)
- dried flowers
- oatmeal
- tiny squares of candied fruit
- a blunt object such as a butter knife
- a cookie tray

What you do

Shred a bar of soap using the grater. Place the large pan on a burner and fill the bottom with enough water to cover the bottom of the small pan that you place inside the large pan. Take care to make sure that the inside of the small pan stays completely dry, and that there's always water in the large pan. Place the grated soap in the small pan. Heat the large pan slowly on a medium flame till the soap melts. Add 1/4 of a cup of strong tea (that you have made) to the soap, mixing it in thoroughly. Spoon the soap mixture onto a cookie tray in six equal measures. Knead, or mill, each soap mixture with a knife. When the soap firms up, add your choice of essential oils using the droppers. Continue to knead until the soap is hard enough to pick up. Form it into a shape, then roll your bar of soap in dried flowers, oatmeal, or candied fruit. Allow the soap to dry completely before you use it.

What's going on?

Soap molecules have both fatty acid and salt-like properties. The latter allow the soap to dissolve in water, while the fatty acid properties allow the soap to dissolve dirt and oils. The combination of the two sets of properties gives soap its ability to dissolve grease in water.



Ellen McCallie is the beneficiary of the sunscreen she concocted, administered by host Kate Humble.

Construct a Sundial

You have to watch how long you wear that facial mask. So let's make a timepiece for the spa.

You need

- sundial template
- a magnetic compass
- card stock
- elastic string with metal ends
- atlas

What you do

Copy the sundial template onto card stock. Fold the tabs to an angle that corresponds to your latitude, as shown on an atlas. Then fold down both tabs to form the base of the sundial. Open your sundial to form a 90-degree angle and fold in the supporting tabs. To finish the dial, attach the elastic string through the holes at the top and bottom at the points where all the hour lines converge. This string is the gnomon (pronounced no-mun) and casts the shadow to indicate the time. To provide accurate time, the sundial (1) must be orientated with the gnomon pointing North/South; (2) must be located where a shadow will be cast by the gnomon most of the day. (Note: one can move the dial from window to window as the day progresses.) For greater accuracy, see the Equation of Time chart on the upper face of the sundial. A magnetic compass may be used to determine the North/South line. Because of the difference between magnetic North and true North, the sundial reading could be off by

an hour or more. The variation will depend on the local difference between magnetic and true North.

What's going on?

Your location on Earth in relation to the sun determines the time where you are. Because the Earth rotates as it travels round the sun, the date is also very important. Compare 5 o'clock in the afternoon in July with the same time in December. Your watch or clock measures standard time. Your sundial records solar time, which is not the same. According to solar time, noon is when the sun is directly overhead. Even though noon in Boston, New York and Miami happens at the same moment in standard time, there would be noticeable differences if you measured noon at all three locations in solar time.

Activity adapted from *Sun Sculpture & Sundial-Making Kit*. New York Hall of Science, 2002. For information on making other sundials, see <http://liftoff.msfc.nasa.gov/> - *Liftoff to Space Exploration: A Space Sciences Project*.

For more activities, see the *Rough Science* Web site: www.pbs.org/roughscience.

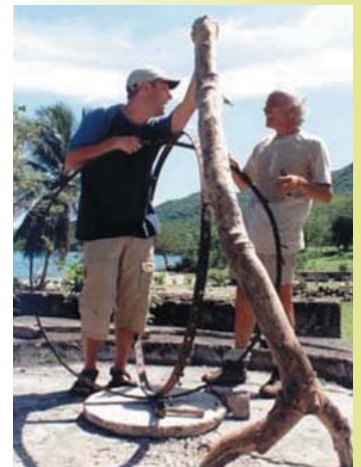

Mike Leahy and Mike Bullivant fashion a sundial.

Create a Facial Mask

Whether your skin is oily or dry, it can benefit from a facial mask. Mixing eggs with mint and honey will make masks suited to oily skin; yogurt and cucumber will help rehydrate dry skin. Put slices of cucumber over your eyes while your mask is drying.

You need

- eggs
- cucumbers
- plain yogurt
- instant nonfat dried milk
- chamomile flowers
- fresh mint and honey
- small bowls
- whisks
- graters

What you do

In a small bowl, mix grated cucumber, yogurt, and dried milk with a whisk to create a moisturizing mask for dry skin. Mix egg, chamomile flowers, fresh mint, and honey with a whisk in another bowl to produce an astringent mask that will tighten pores in oily skin. Apply the mask that matches your complexion to your face for 15 minutes, and then rinse it off with warm water.

What's going on?

The yogurt mask increases the flow of sebum (oil produced by glands in your skin) by causing your skin tissue to expand. The astringent (an agent that contracts tissue to reduce secretions) mask made from mint shrinks skin tissue and reduces the sebum flow.

Tropical Island Party

On vacation let your hair down. What better place for a party than a tropical island paradise? But who would have thought that rough science could help make you the perfect host?

The Challenges!

For original invitations, [make your own paper](#).

To wake up the party poopers, create botanical [noisemakers](#).

For refreshments, offer [homemade ice cream and soda](#).

Make Paper

You need to let people know when and where to come to the party. But first you'll need some paper to write your invitations.

You need

plain office paper, newspaper, magazines, egg cartons, toilet paper, paper bags, old cards, nonwaxed boxes pre-soaked in warm water, tissue paper, napkins, or construction paper (any of these types of paper or a mixture)
sponge
screening from a window or door
an old picture frame or other wooden frame
plastic tub large enough to accommodate the wooden frame
blender or food processor
white felt or flannel fabric
staples or tacks
liquid starch
2 cookie sheets

What you do

Rip the paper into small pieces and place it in a blender until half full. Fill the blender up with warm water. Blend slowly until there is no trace of paper and the pulp is smooth. Staple the screen to the frame as tightly as possible to make a deckle. Fill half the basin with water and add 3 blenders-full of pulp. (For thicker paper, add more pulp.) Stir well and add 2 teaspoons of liquid starch. Submerge the deckle in the pulp and gently shake it until you have an even covering on top of the screen. Lift the deckle above the water level and let it drain off. (If the new paper on top of the screen is too thick, take some pulp out of the tub. If the paper is thin, add more pulp and re-stir.) When the deckle stops dripping completely, carefully place one edge along an edge of fabric and gently ease the paper out of the deckle on top of the fabric. Press out as much water as possible with the sponge. Make sure the paper has come apart completely from the deckle. Stack the fabric and paper pieces on a cookie sheet. Put a piece of fabric on top of the top sheet of paper and cover the pile with another cookie sheet. Press well to remove any remaining water. Gently separate the sheets of paper and hang them in the sun, or lay them on sheets of newspaper, until they are dry.

Make Ice Cream

What's a tropical party without ice cream? Take the temperature down a degree or two by making your own chocolate ice cream.

You need

cream cocoa powder
milk tablespoon
ice cubes salt
dish towel large glass bowl

What you do

In the glass, mix one spoon of cocoa powder, two spoonfuls of milk, and one spoonful of cream. Put some ice in the bowl and cover it with lots of salt. Put the glass on top of the ice and pack ice around the glass.

Cover all the ice with salt. Place the dish towel over the bowl and leave the ice cream mixture to set for an hour. *Voilà* – delicious chocolate ice cream!

What's going on?

The salt lowers the freezing temperature of the ice. This actually makes the ice colder. The ice absorbs heat from the ice cream mixture. The ice cream gets colder and colder until it eventually freezes.

How about using flavors other than chocolate? Lemon, vanilla, orange, or raspberry?

What's going on?

Paper is made from plant fibers - old rags, trees. By chopping up the paper, you are recycling the fibers in the old paper to make new paper. The liquid starch helps to prevent inks from soaking into the paper fibers. For more information on making paper, see <http://www.pioneer-thinking.com>.

Make Lemon or Orange Soda

Throwing a party is thirsty work! You'll need something to quench your thirst and give you the energy to keep dancing all night. Make a refreshing soda from a few simple ingredients.

You need

- a lemon or orange
- a glass
- water
- sugar
- 1 teaspoon baking soda

What you do

Squeeze a lemon or orange and put the juice in the glass. Add an equal volume of water and some sugar till your drink tastes sweet enough. Stir in the baking soda and stand back as your drink fizzes.

What's going on?

Baking soda is a chemical compound called a carbonate. Lemon and orange juices contain acids. When a carbonate and an acid are mixed, they produce a salt. Baking soda is a buffer. In the presence of an acid, carbon dioxide gas is released, producing the bubbles in your drink. A similar reaction, producing carbon dioxide, is used in certain fire extinguishers.

Additional scenarios, activities, and ideas can be found on the *Rough Science* Web site: www.pbs.org/roughscience.

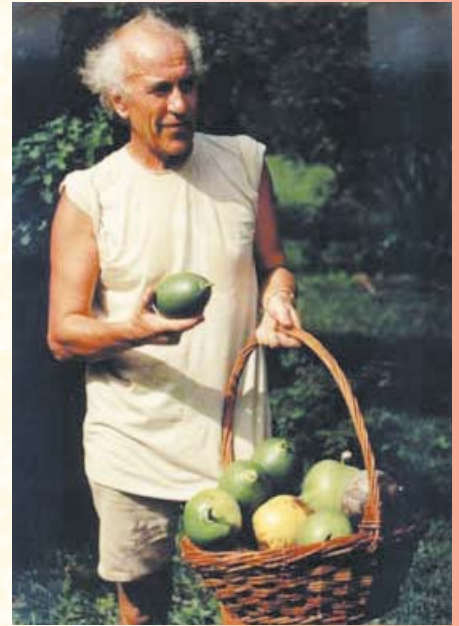

Mike Bullivant seeks sustenance for the team with calabash fruit.

Make Botanical Noisemakers

You don't want anyone to miss the fun! Let everyone know where the party is with some rattles, shakers, and other noisemakers.

You need

- dried beans, peas, rice, nuts in shells, or other dry seeds
- 2 aluminum pie plates
- empty film canisters and lids
- empty plastic bottles and lids
- craft sticks
- tape
- scissors

What you do

Place a handful of beans, peas, nuts, or seeds between two pie plates and then tape the plates together around the edges. Use a pair of scissors to make small slits in the bottom of the canisters, and insert craft sticks through the holes. Put different amounts of rice inside the film canisters and put on the lids. Put other plant materials inside the plastic bottles. Shake them to different rhythms.

What's going on?

Sounds come from vibrations. Shaking the noisemakers causes the beans, rice, or other plant materials to hit against the pie plates and vibrate, thus creating sound.

Activity adapted from Jill Frankel Hauser and Loreta Trezzo Brare. *Kid's Crazy Concoctions*. Williamson Publishing, 1998.

Suggestions for other activities

To make sounds like a horn, recorder, drum, and whistle, make musical instruments from natural materials (willow sticks, vines, tree branches, shells, blades of grass).

To have neat jewelry to wear, make bracelets and rings from plants.

THE ROUGH SCIENTISTS

Mike Bullivant – chemist

Mike Bullivant works part-time as a course manager in the chemistry department at the Open University and part-time as a TV/video/CD-ROM/radio presenter. Bullivant studied chemistry as an undergraduate at the University of Wales (Cardiff) and went on to do research for a doctorate in organic photochemistry at the Universities of Cardiff and Nottingham.

Vanessa Griffiths – biologist (episodes 7-10)

Longing as a child to be the next Jacques Cousteau, Vanessa Griffiths followed her passion to become a marine biologist, earning her degree in marine biology at Liverpool University. After college Griffiths spent a year doing field research at the marine station on the Isle of Man, then went on to get her master's degree and teaching certificate. She now teaches ecology at the Orielton Field Center in Pembrokeshire in the United Kingdom, where she has introduced hundreds of school children to the vast marine life that can be found in an afternoon at the beach.

Jonathan Hare – physicist

Jonathan Hare studied physics at Surrey University. During his doctoral studies in chemical physics at Sussex University, he was involved in some of the first pioneering work on Buckminsterfullerene, the 60-atom molecule that earned a Nobel Prize for its discoverers. This work led from astronomy via chemistry into a new area of material science. Hare currently manages The Creative Science Center and is part of the Vega Science Trust at the University of Sussex, which creates science programming for television and the Internet. He also works as a consultant on educational programs for multinational corporations.

Mike Leahy – biologist

Mike Leahy left school by "mutual agreement" while studying for his final high school exams and began an apprenticeship as a motor mechanic. Leahy was an active member of the environmental movement during the late 1980s and early 1990s, and while still a mechanic, he studied for a biology degree at night school. At the age of 26, armed with a high school degree, he left his work in mechanics to study for a degree in environmental biology at Oxford Brookes University and gained a honors degree within two years. Leahy moved on to Oxford University where he earned a doctorate in virology. With 14 publications in international journals, he is now considered a leader in the field of influenza virus replication.

Anna Lewington – botanist (episodes 7-10)

A writer and educator, Lewington is perhaps best described as a ethnobotanist for her studies of the ways plants are used by various peoples of the world – from the indigenous tribes of the Amazon rainforest to our own modern culture. She graduated from Birmingham University and earned her master's degree from St. Andrews University. Lewington has authored numerous books and articles on the ways humans use plants.

Ellen McCallie – biologist (episodes 1-6)

Ellen McCallie grew up in St. Louis and is a tropical ecologist and educator. She spent a year in Bogor, Indonesia, as an American Field Service (AFS) exchange student before attending Grinnell College in Iowa, where she earned a bachelor's degree in biology with a concentration in environmental science. McCallie then spent a year as a Fulbright scholar, conducting research on the pollination of agroforestry trees in the Amazon basin. Her graduate research was conducted in Timor, Indonesia, focusing on alternatives to slash-and-burn agriculture. McCallie became the first education curator of the Sophia M. Sachs Butterfly House and Education Center in St. Louis before starting her own elementary science curriculum business. She is currently the coordinator of interpretation in the education division at the Missouri Botanical Garden in St. Louis.

Kathy Sykes – physicist (episodes 1-6)

Kathy Sykes is a science communicator working on a variety of projects, including serving as director of the Cheltenham Festival of Science in the United Kingdom. She was previously head of science for Explore@Bristol, a new hands-on science center, developing ideas for the content of the institution. Sykes is a physicist, with a doctorate from Bristol University and is still doing post-doctoral research there. She completed her first degree there before going to teach math and physics in Zimbabwe for three years.

ROUGH SCIENCE EPISODES

Led by host Kate Humble, five scientists are challenged to put their collective scientific knowledge to practical use. Transported to isolated locations, they are presented with a series of tasks, with two notable restrictions: they must complete their work within three days and, with the exception of a rudimentary tool kit, they must use only indigenous materials. A synopsis of each episode is provided below along with brief details of the science challenges (indicated in bold type).

Episode 1 - Mapping it Out

Kate Humble and the team of five scientists take up the challenge of charting the sights and sounds of their tropical island. Starting from scratch, they have to **make an accurate scale map, botanical paper and inks**, and a **sound-recording device**. The team members have very good heads for math and plenty of versatile local plants to get them started, but impassable mangrove swamps and tropical downpours soon seem intent on scuttling their plans.

Episode 2 - Bugs and Barometers

The team has to pit their wits against nature - and bugs - in the latest challenge. Can they get a **biology lab (antibacterial cream), microscope** and **weather station (barometer, hygrometer, anemometer)** built and tested on their tropical island? With only a basic toolkit to work with, the island's plants and seaweed have to be employed - and with nothing but clear skies weather forecasting can still be a little problematic.

Episode 3 - Time and Transmitters

The scientists find they have to borrow some wartime tricks when challenged with building a **transmitter and radio** - but will they be able to communicate across their tropical island base? There's also an accurate **portable clock** and a **botanical kite** to design, and, once again, the island's natural plants and resources get the scientists thoughts running in strange new directions.

Episode 4 - Feel the Heat

The challenges don't come much tougher than this as the team of scientists tackles the task of lowering the temperature on their sweltering tropical island base. The chemistry of cooling paradoxically seems to involve heating things up first. With just three days to complete the task of **making ice**, as well as producing working **thermometers** and **sunscreen**, their patience is soon simmering.

Episode 5 - Sun and Sea

The challenge of building an **underwater light** to examine the marine life around their tropical island base finds the team grappling with **natural power sources** (filaments and phosphorus from cow bones). The scientists find they need a little human elbow grease to **generate electricity** to **charge up a battery**.

Episode 6 - Science of Celebration

The science of sound and fireworks helps the team devise ways of going out with a bang in the last set of challenges on their Caribbean island. Tasked with **creating a concert** and spectacle to light up the Caribbean night sky, the scientists find they are struggling to find harmony, while their **pyrotechnics** seem to generate more heat than light. Can they turn it around to stage a spectacular finale?

Episode 7 - Mediterranean Mystery

Swapping their high-tech labs for a disused prison, the five scientists are ferried to a mystery Mediterranean island where they must pool their collective wits. Can they work out their exact **latitude and longitude**, **manufacture an insect repellent** from scratch, and **improvise a radio** from an old saucepan?

Episode 8 - Simmering Shutterbugs

Our scientists have worked out where they are on the globe, but can they now master a series of science-based challenges using just the natural resources of the island? Can they **improvise a low-tech camera and film**, **make a compass** to get their bearings, and **dye a flag**. Seawater, seaweed and urine prove to be indispensable ingredients, but things don't quite go to plan.

Episode 9 - Power Supplies

In this episode, two of the team go head to head in a race to **generate power**, while the others set about **building a pharmacy**. They extract and dispense a string of **natural remedies**, including an **antiseptic** made from myrtle and olives, and an **anti-flatulent** from fennel seeds.

Episode 10 - Sustenance and Sayonara

Wrapping up their stay on their isolated Mediterranean island, the scientists face the challenge of using their science skills to put **food** on the table. One of them faces an epic struggle to **make soap** to clean the dishes, while two other team members improvise **toothpaste** from seaweed, seashells and mint. They also try to **make a record player**.



Kathy Sykes feels success is at hand in the creation of an underwater flashlight.

Books

- Ardley, Neil. *101 Great Science Experiments*. Dorling Kindersley, 1993.
- Bosak, Susan. *Science is...: A Sourcebook of Fascinating Facts, Projects and Activities*. Reprint ed. Firefly Books. 2000.
- Browning, Marie. *Natural Soapmaking*. Sterling Publications, 1999.
- Day, John A., Shafer, Vincent J., and Peterson, Roger Tory. *Peterson First Guide to Clouds and Weather*. paperback. Houghton Mifflin Co., 1998.
- Doherty, Paul, and Rathjen, Don, eds. *Science Snackbook: Teacher Created Versions of Exploratorium Exhibits*. The Exploratorium, 1991.
- Graf, Rudolph F., and Sheets, William. *Build Your Own Low-Power Transmitters: Projects for the Electronics Experimenter*. Newnes, 2001.
- Greene, Alan. *Primitive Photography: A Guide to Making Cameras, Lenses and Calotypes*. Butterworth-Heinemann (Trd), 2001.
- Harris, James G., and Harris, Melinda Woolf. *Plant Identification Terminology: an Illustrated Glossary*. Spring Lake Pub., 2001.
- Hauser, Jill Frankel, and Braren, Loretta Trezzo. *Kids' Crazy Concoctions*. Williamson Publishing, 1998.
- Hodgson, Michael. *Basic Essentials: Weather Forecasting*. 2nd ed. Globe Pequot Press, 1999.
- Home Made Best Made: Hundreds of Ways to Make All Kinds of Useful Things*. Reader's Digest General Books. Reader's Digest Adult, 1998.
- Kerrod, Robin, and Holgate, Sharon Ann. *The Way Science Works*. DK Publishing, 2002.
- Lawrence Hall of Science. *Earth, Moon, and Stars*. Regents of the University of California, 1986.
- _____. *Electricity*. Regents of the University of California, 1983.
- _____. *Height -O-Meters*. Regents of the University of California, 1988.
- _____. *Hot Water and Warm Homes from Sunlight*. Regents of the University of California, 1986.
- _____. *Of Cabbages and Chemistry*. Regents of the University of California, 1989.
- _____. *Secret Formulas*. Regents of the University of California, 1996.
- Levabre, Marcel. *Aromatherapy Workbook*. Inner Traditions International Ltd., 1997.

- Liles, J.N. *The Art and Craft of Natural Dyeing: Traditional Recipes for Modern Use*. University of Tennessee Press, 1990.
- Mayall, R. Newton and Mayall, Margaret W. *Sundials: Their Construction and Use*. Dover, 2000.
- McGee, Harold. *The Curious Cook: More Kitchen Science and Lore*. John Wiley & Sons, 1992.
- Miller, Susan. *The Soapmaker's Companion: A Comprehensive Guide with Recipes, Techniques, and Know How*. Storey Books, 1997.
- Monihan, Kevin, and Douglass, Don. *GPS Instant Navigation: From Basic Techniques to Electronic Charting*. Fine Edge Productions, 2000.
- Murray, Michael T., and Pizzorno, Joseph. *Encyclopedia of Natural Medicine*. Prima Publishing, 1997.
- Rogers, Kirsteen, and Dowsnell, Paul. *The Usborne Complete Book of the Microscope*. EDC Publications, 1997.
- Trionfante, Jeffrey V. *Sunclocks: Sundials to Make and Use*. Jvt Publishers, 1999.
- Wood, Robert. *Science For Kids: 39 Easy Meteorology Experiments*. TAB Books.

Web sites

Astronomy & Space

- <http://www.astrosociety.org/education>
<http://spacelink.nasa.gov/>
<http://spaceplace.jpl.nasa.gov/spacepl.htm>
<http://spacescience.nasa.gov/education/educators/index.htm>
<http://science.nasa.gov/ssl/pad/solar/sunspots.htm>

Biology/Botany

- <http://www.herbalgram.org>
<http://www.herbal-medicine.org>
<http://www.herbreferance.com>
<http://www.wilderness.org>
<http://www.worldwildlife.org>

General Science & Technology Activities

- <http://www.col-ed.org/cur/science.html>
<http://www.exploratorium.org>
<http://www.ology.amnh.org/>
<http://www.windows.ucar.edu/tour/link=/windows3.html&edu=high>
<http://www.howstuffworks.com>

Metric Conversion

- <http://www.pbs.org/roughscience> (interactive metric converter)
<http://www.pbs.org/wgbh/nova/unitsprint.html> (printable conversion chart)

Sound & Electricity

- <http://www.smm.org/sound>

Timekeeping & Sundials

- <http://www.physics.nist.gov/time>

Weather

- <http://www.nasa.gov>
<http://www.noaa.gov>
<http://www.oceanconvservancy.org>



Rough Science is a co-production of the BBC and Open University in association with WETA Washington, D.C. Major funding is provided by the National Science Foundation. Corporate funding is provided by DuPont.

Rough Science was supported, in part, by the National Science Foundation. Opinions expressed are those of the authors and not necessarily those of the Foundation.

© Greater Washington Educational Telecommunications Association, 2002